

Pt100 converter, loop-powered

3333

- High accuracy, better than 0.1% of span
- Slimline housing of 6 mm
- Excellent EMC performance and 50/60 Hz noise suppression
- Selectable < 30 ms / 300 ms response time
- Pre-calibrated temperature ranges selectable via DIP-switches



Application

- The 3333 temperature converter measures a standard 2-, 3- or 4-wire Pt100 temperature sensor, and provides a passive analog current output signal.
- The 3333 can be mounted in the safe area or in Zone 2 / Division 2 areas.
- Approved for marine applications.

Technical characteristics

- Flexibly loop powered by 3.3...35 VDC via connectors.
- < 30 ms fast response time with simultaneous sensor error detection when selected.
- Selectable 300 ms response time when signal dampening is needed.
- High conversion accuracy in all available ranges, better than 0.1% of span.
- Meeting the NAMUR NE21 recommendations, the 3333 provides top measurement performance in harsh EMC environments.
- The device meets the NAMUR NE43 standard defining out of range and sensor error output values.
- All terminals are protected against overvoltage and polarity error.
- Excellent signal/noise ratio of > 60 dB.

Mounting / installation / programming

- Selectable DIP-settings for easy configuration of more than 1000 factory calibrated measurement ranges.
- The narrow 6 mm housing allows up to 165 units to be mounted per meter of DIN rail, without any air gap between units.
- Wide ambient temperature range of -25...+70°C.

Applications

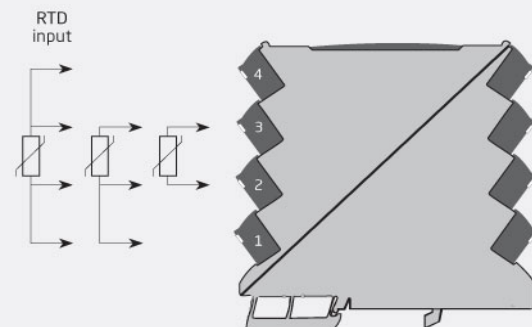

Safe Area or
Zone 2 & Cl. 1, Div. 2, gr. A-D

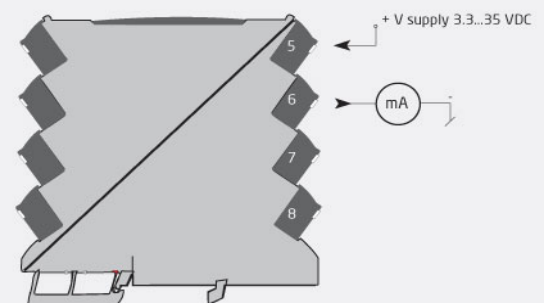

Order:

Type
3333

Environmental Conditions

Operating temperature.....	-25°C to +70°C
Storage temperature.....	-40°C to +85°C
Calibration temperature.....	20...28°C
Relative humidity.....	< 95% RH (non-cond.)
Protection degree.....	IP20
Installation in.....	Pollution degree 2 & meas. / overvoltage cat. II

Mechanical specifications

Dimensions (HxWxD).....	113 x 6.1 x 115 mm
Weight approx.....	70 g
DIN rail type.....	DIN EN 60715/35 mm
Wire size.....	0.13...2.5 mm ² / AWG 26...12 stranded wire
Screw terminal torque.....	0.5 Nm
Vibration.....	IEC 60068-2-6
2...25 Hz.....	±1.6 mm
25...100 Hz.....	±4 g

Common specifications**Supply**

Supply voltage.....	3.3...35 VDC
Max. required power.....	0.80 W
Internal power dissipation.....	12 mW...0.8 W

Response time

Response time (0...90%, 100...10%).....	< 30 ms / 300 ms (selectable)
---	-------------------------------

Voltage drop.....	3.3 VDC
Signal / noise ratio.....	Min. 60 dB
Programming.....	DIP-switches
Signal dynamics, input.....	23 bit
Signal dynamics, output.....	18 bit
EMC immunity influence.....	< ±0.5% of span
Extended EMC immunity: NAMUR NE21, A criterion, burst.....	< ±1% of span
Incorrect DIP-switch setting identification.....	3.5 mA

Input specifications**RTD input**

Temperature range, Pt100.....	-200...+850°C
Min. measurement range (span).....	10°C
Accuracy: the greater of.....	Better than 0.1% of span or 0.2°C

Temperature coefficient: the greater of.....	0.02°C/°C or ≤ ±0.01%/°C
Sensor current.....	< 150 µA
Sensor cable resistance.....	< 50 Ω per wire
Effect of sensor cable resistance (3-/4-wire).....	< 0.002 Ω / Ω
Sensor error detection.....	Yes - selectable via DIP- switch
Broken sensor detection.....	> 800 Ω
Shorted sensor detection.....	< 18 Ω

Output specifications**Common output specifications**

Updating time.....	10 ms
--------------------	-------

Current output

Programmable signal ranges.....	4...20 and 20...4 mA
Load (@ current output).....	≤ (Vsupply - 3.3) / 0.023 [Ω]

Load stability.....	≤ 0.01% of span / 100 Ω
---------------------	-------------------------

Sensor error indication.....	3.5 mA or 23 mA / acc. to NAMUR NE43 or OFF
------------------------------	--

I.S. / Ex marking

ATEX.....	II 3 G Ex ec IIC T4 Gc
IECEX.....	Ex ec IIC T4 Gc
FM, US.....	Cl. I, Div. 2, Gp. A, B, C, D T4 or Cl. I, Zone 2, AEx nA IIC T4
FM, CA.....	Cl. I, Div. 2, Gp. A, B, C, D T4 or Cl. I, Zone 2, Ex nA IIC T4
EAC Ex.....	2Ex nA IIC T4 Gc X

Observed authority requirements

EMC.....	2014/30/EU
LVD.....	2014/35/EU
ATEX.....	2014/34/EU
RoHS.....	2011/65/EU
EAC.....	TR-CU 020/2011
EAC Ex.....	TR-CU 012/2011

Approvals

ATEX.....	KEMA 10ATEX0147 X
IECEX.....	KEM 10.0068X
c FM us.....	FM17US0004X / FM17CA0003X
c UL us, UL 61010-1.....	E314307
EAC Ex.....	RU C-DK.HA65.B.00355/19
DNV Marine.....	TAA00001RW